

TAPE AND REEL DETAILS - SMD

Tape (mm)

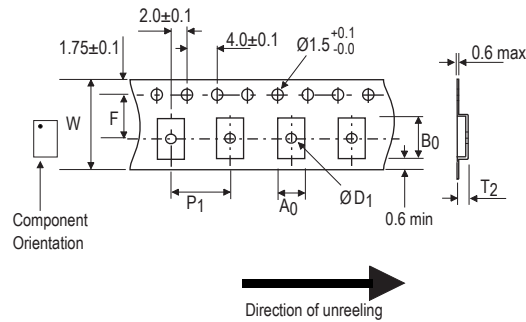

Reel (mm)

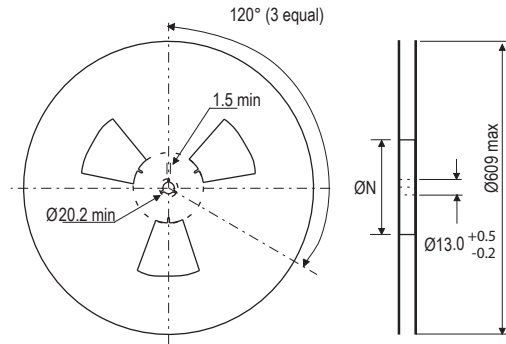

Cut outs are shown for indication only

Generic Package Size	Generic Tape Width	W (max)	F	A ₀ (typ)	P ₁ (typ)	B ₀ (typ)	D ₁ (min)	N (min)	T ₂ (max)
1.6 x 1.2	8	8.3	3.5±0.05	1.7	2	1.9	-	50	2.5
2 x 1.6	8	8.3	3.5±0.05	2.2	2	2.4	-	50	2.5
2.5 x 2	8	8.3	3.5±0.05	2.5	4	3.0	1	50	2.5
3.2 x 2.5	8	8.3	3.5±0.05	3.0	4	3.7	1	50	2.5
5 x 3.2	12	12.3	5.5±0.05	4.3	8	5.5	1.5	50	6.5
6 x 3.5	12	12.3	5.5±0.05	4.0	8	6.5	1.5	50	6.5
7 x 5	16	16.3	7.5±0.1	6.0	8	8.0	1.5	50	16.3
14 x 9.8	24	24.3	11.5±0.1	10.8	12	15.0	1.5	60	24.3

Leader and Trailer

- There shall be a leader of 400mm minimum of cover tape, which includes at least 100mm of carrier tape with empty compartments sealed by the cover tape. All of the leader may consist of the carrier tape with empty compartments sealed by cover tape.
- There shall be a trailer of 160mm minimum of empty carrier tape sealed with cover tape. The entire carrier tape shall release from the reel hub as the last portion of the tape unwinds from the reel without damage to the carrier tape and the remaining components in the cavities.

Bend Radius

- The tape shall pass around a bend with radius 30mm without damage.

Camber

- Not more than 1mm lateral movement across 250mm length of tape.

References

- All dimensions based on international standard EIA-481-D.

Statek Product

- For specific details on Statek's tape and reel specifications, please refer to the technical information on the IQD Statek website at www.iqdstatek.com/app-notes/