

IQD Advanced Clock Modules

This application note introduces IQD Frequency Product's range of advanced clock modules which provide electrical timing functionality for distributed network systems. These units primarily revolve around the 1PPS (pulse per second) timing synchronisation signal produced by a GPS receiver which is derived from transmitted timing information received from GPS satellite systems.

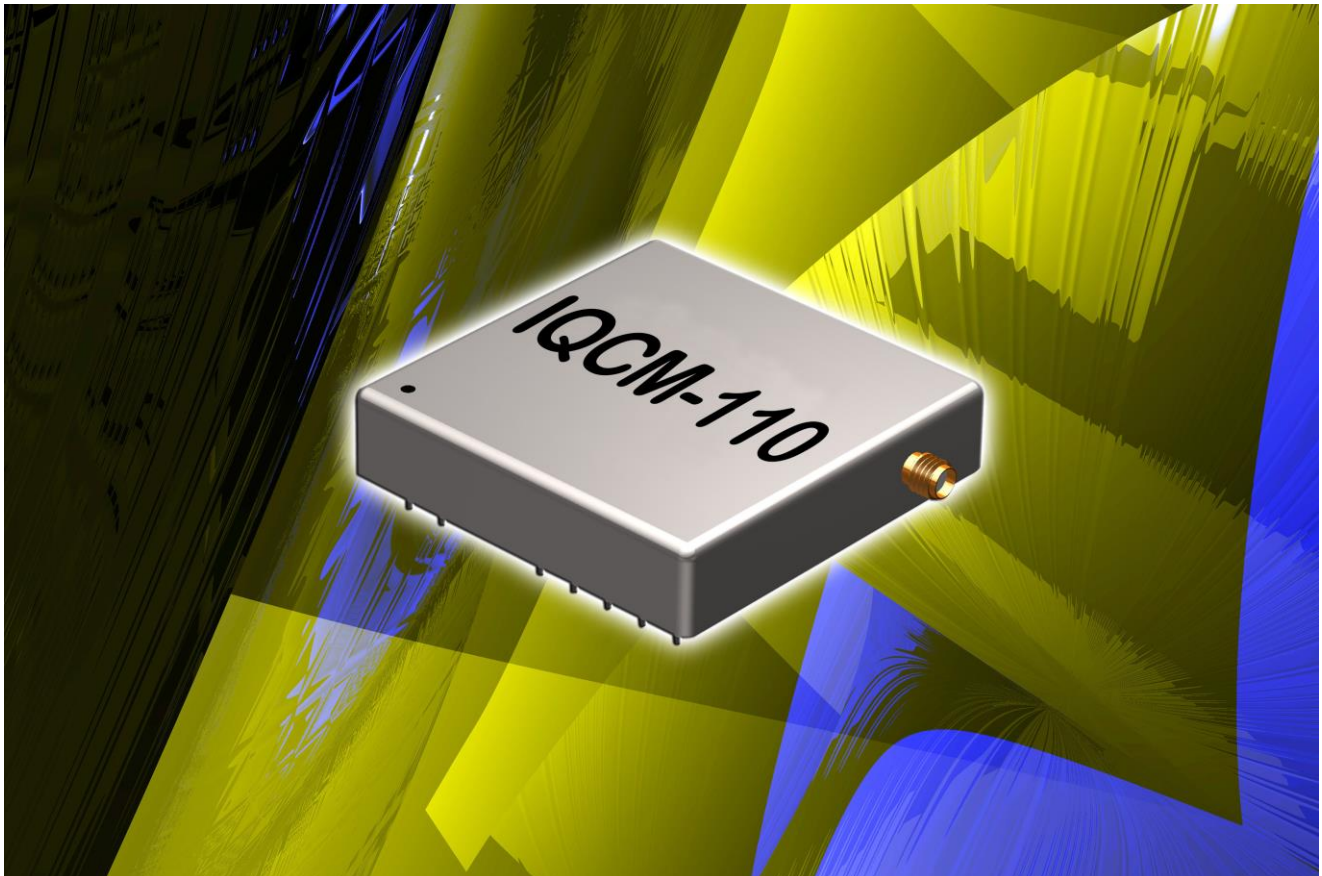

Summary Table of Clock Module Functions										
Function	1PPS output	1PPS input	10MHz output	Internal GPS	Holdover 1.5µs over 24hrs	NMEA Rx/Tx	IEEE 1588	SGMII & SPI	UART/RS232	Aerial input
Module										
IQCM-100	✓	✓	✓	-	✓	-	-	-	✓	-
IQCM-110	✓	-	✓	✓	✓	✓	-	-	-	✓
IQCM-200	✓	✓	✓	-	*	-	-	-	✓	-
IQCM-300	✓	✓	✓	-	✓	-	✓	✓	✓	-
* The IQCM-200 is intended for reduced holdover spec applications.										



Clock Module Summary Information

IQCM-100

This main module is designed to provide both 1PPS and 10MHz output signals with a holdover stability of $\pm 1.5\mu\text{s}$ over a 24hr period to meet telecom standard requirements for applications such as LTE-TDD. The IQCM-100 requires a separate customer supplied 1PPS signal from a GPS receiver.

IQCM-110

The IQCM-110 module has similar functionality to the IQCM-100 except that it has a built-in GPS receiver unit. The customer however must provide a suitable aerial connected to the SMA connector on the device. Active antenna is recommended.

IQCM-200

This module also has similar functionality to the IQCM-100 device but is available with relaxed holdover specifications of increased times or smaller temperature variation limits to address applications where $\pm 1.5\mu\text{s}$ over 24hrs is not critical.

IQCM-300

This module provides PTP (Precision Time Protocol) functionality based on IEEE1588.

PTP or IEEE1588 is a protocol used to send accurate timing synchronisation between different locations on a network. The IQCM-300 is capable of acting as a 'Grand Master clock' within a system or as a 'Slave clock' and as such is capable of passing synchronisation messages to other clocks in the system. This module provides the same holdover capability as the IQCM-100 but has the added functionality that it can communicate across the PTP 1588 network. The IQCM-300 requires a separate customer supplied GPS receiver.

Typical Applications include:

- 3G/4G LTE Base-stations
- Clock Server
- Clock Source
- IP Backhaul
- PTP Server
- Radar
- Smart Power Grid
- Test & Measurement



Application Considerations

The main objective of these modules is to maintain the 1PPS (pulse per second) signal of the GPS system and is used in communication network systems to synchronise timing. If your system relies on the GPS signal to maintain accuracy and the GPS signal fails due to loss of lock, bad weather, jamming or other issues then these clock modules are able to keep the 1PPS signal maintained until GPS lock is restored, enabling your network system to remain within specification.

What specification module do I require?

In order to decide which module is suitable for your specific application then various parameters need to be considered such as:

- a/ What holdover spec does my system require?
- b/ Over what time period will I be without the GPS signal?
- c/ What environmental conditions will the module see when experiencing the loss of GPS signal?

Why 1.5µs in 24hrs?

To fully meet the requirements of some specific telecoms protocols such as LTE, your product will have to show that it can maintain accuracy to within $\pm 1.5\mu\text{s}$ over 24hours if the GPS signal is lost.

However, some systems may not require this level of holdover and thus if this value can be relaxed then the unit cost can be reduced. Remember not to over-specify this parameter if it is not required.

Environmental change during holdover mode

These clock modules use an OCXO in combination with software algorithms to maintain their 1PPS accuracy during periods of no GPS signal and so it is important to understand what temperature changes will be seen by the module during loss of GPS.

If your equipment will be used in an air-conditioned room then the temperature changes may be very small, perhaps $\pm 2^\circ\text{C}$. However if the module is sited at for example the base of an aerial then it may experience a much wider temperature change during this no GPS period.

It is important to understand that the holdover temperature specification is not the same as the operating temperature range. The operating temperature range could be 0 to 70°C but the holdover change of temperature during no GPS signal may be only $\pm 2^\circ\text{C}$ to achieve the required $1.5\mu\text{s}$ over 24hr limit. This means that the module can be operated at any specific temperature within it's operating range but when GPS signal is lost, the module must then remain within it's much smaller holdover temperature range of for example $\pm 2^\circ\text{C}$ in order to stay within $1.5\mu\text{s}$ over 24hr.

Since the holdover temperature needs to be compensated for, the larger the change of temperature during loss of GPS then the harder the compensation becomes thus affecting unit cost.

Holdover time period during loss of GPS signal

For applications where the GPS signal will not be lost for a full 24hrs, e.g. 8hrs, then there is no need to specify the clock module with its full holdover time. This relaxation in specification affects the unit cost so remember not to over-specify this parameter if it is not required.

Questions & Answers

What are the requirements for the aerial of the clock module IQCM-110?

In order to get the best performance, choose a maritime dome-type aerial. The connecting cable from the aerial to the clock module should be less than 10m. As shown in the following diagram, the aerial should be placed in an open space which will help the clock module find the satellite signal otherwise it may affect the performance or even normal working status of the clock module.

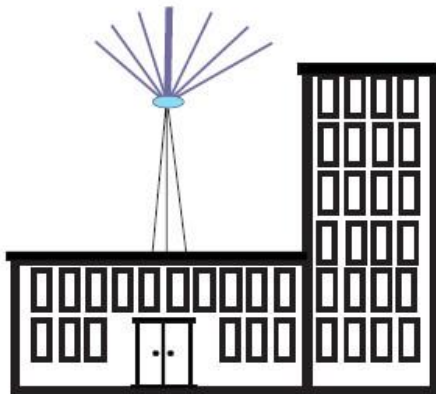

Correct aerial placement

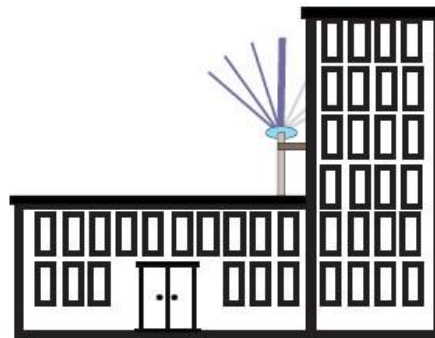

Incorrect aerial placement

2. What are the specifications of the embedded oscillator if the clock module wants to keep the 1.5µs/24h holdover?

Calculation:- 24hrs x 60min x 60sec = 86400seconds

The 24-hour-drift must be less than holdover/secs in 24hrs, i.e. $1.5E-6/86400 = 1.74E-11$.

There are two main factors affecting the OCXO 24-hour-drift:

1. OCXO temperature stability
2. OCXO ageing per day

To achieve $1.74E-11$ stability, we choose tight specification oscillators and use an algorithm to compensate for ageing drift which generally optimizes the device by about 100 times.

3. When the working temperature range changes; does the temperature drift of the DAC and other components affect the whole system clock accuracy?

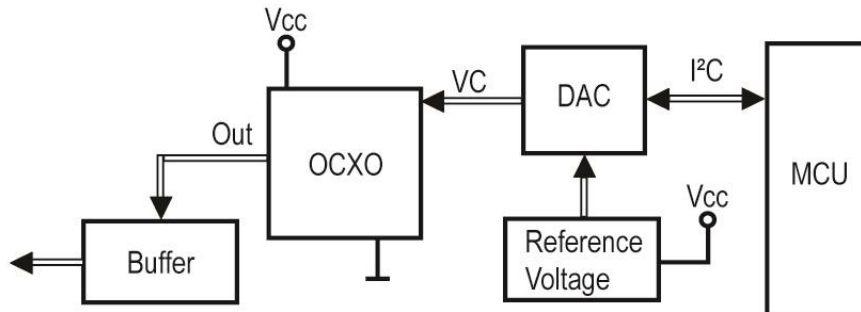

The diagram above shows the general design of oscillator control block. The OXCO's control voltage is changed by the DAC which is controlled by the MCU. From a design perspective and knowing when the operating temperature change is sharp then we should consider the impact of temperature drift of the DAC and reference voltage. The operating temperature range is assumed to be 0+60°C

For example, precision 16bit DAC8571 has a temperature drift coefficient of -5ppm of FSR/°C (typical) so for a temperature change of 0 to 60°C, the voltage reference change is: $60 \times 5\text{ppm} \times 3.0\text{V} = 0.9\text{mV}$

This voltage reference change impacts on the DAC which then alters the frequency of the OXCO.

Using precision voltage reference REF3230 as example, the REF3230 output voltage temperature drift specifications are: 0°C to 125°C, 4 to 7ppm/°C and -40°C to 125°C, 10.5 to 20ppm/°C

Using the example temperature change of 0 to 60°C, the voltage reference change is:

$60^\circ\text{C} \times 7\text{ppm} \times 3.0\text{V}$ (pull range of OXCO) = 1.26mV

The total drift thus becomes: $0.9\text{mV} + 1.26\text{mV} = 2.16\text{mV}$

Based on an oscillator pulling range of $\pm 0.4\text{ppm}$ over a control voltage of 0~3.0V, the oscillator drift caused by the temperature drift of voltage reference and DAC is:

$(0.8\text{ppm pk-pk} / 3\text{V}) \times 2.16\text{mV} = 5.76\text{E-}10\text{ppm}$, far more than $1.74\text{E-}11\text{ppm}$ needed to meet the $1.5\mu\text{S}/24\text{h}$ holdover.

In order to solve these problems, the temperature control circuits of the highly stable oscillator uses its own proprietary technologies to improve the control accuracy to make sure that when the temperature changes, the accuracy of the oscillator is maintained.

By analysis, the total drift of this design is only $9.6\text{E-}13$, including the voltage reference and DAC drift which meets the LTE $1.5\mu\text{S}/24\text{h}$ holdover requirements. The circuit also ensures that the product does not show the phenomenon of rapid frequency variation (temperature control is not enough) when the working temperature changes rapidly.



4. Insight into how the internal algorithm works

After losing connection with the GPS signal, some key factors are used to calculate the correct OCXO control voltage:

- 1) The signal just before the GPS is lost is usually unstable and therefore these reference records from the GPS need to be removed.
- 2) If the environment temperature change is cyclical then the unit should have collected at least one cycle of data for modelling. If there is an obvious cyclical variation then the unit will analyse according to its specific circumstances.
- 3) The ageing curve is relatively steep during the first 3 days after the OCXO is powered up and after this it levels off so the longer the OCXO is powered up, the better for modelling purposes. For modelling the behaviour it is best to use twice the projected time. Therefore for the best results the unit will use two day's data to extrapolate one day's data, otherwise the compensation may be excessive and the accuracy may deteriorate.

5. How to measure the holdover of the clock module?

There are generally two ways to measure the clock module holdover:

- 1) Measure with an external standard 1PPS signal.

After 7 days of power-on and 3 days locked to a standard 1PPS GPS received signal (atomic level accuracy), the clock module without a GPS receiver inside is disconnected. The 1PPS output signal of the clock module and an external GPS derived 1PPS signal are then connected to an oscilloscope. The difference in values of the two signals can then be observed and compared after a predetermined time.

- 2) Measure with the internal 1PPS standard. (this method is only applicable to the IQCM-110 clock module with a built-in GPS receiver).

After 7 days power-on and 3 days locked to GPS signal, the clock module is forced to holdover status in which the clock module still provides the standard 1PPS output signal but the internal high-stability oscillator does not follow the standard 1PPS GPS derived signal to adjust the frequency and phase of the clock module. Then connect both the standard 1PPS GPS derived signal and the 1PPS output signal of the clock module (in holdover mode) to an oscilloscope. The difference in values of the two signals can then be observed and compared after a predetermined time.

6. If the clock module produces a lot of heat, can we cool it? Will the accuracy be affected by the cooling? What method can be taken?

The temperature of an OCXO oven can be 85°C when the oscillator operating and fan cooling will not affect the oscillator when the wind speed is less than 1.7m/s. However if the wind speed changes rapidly when the fan is turned on and the wind speed is faster than 1.7m/s, then the heating control of the oven will be unable to function correctly. This results in temperature instability and the oscillator stability decreasing. The wind speed should be strictly controlled, keeping the entire ambient temperature stable during the cooling.



7. Can the clock module respond to a change in the leap second?

The clock module will ensure the accuracy of the current UTC time on condition that the GPS receiver has the leap second information. Time information received by the GPS receiver is converted to UTC time information after conversion and adjusting for leap seconds. Leap second information will be available in 12.5 minutes on the condition of a good satellite signal to provide accurate time information.

Usually the current leap seconds are known and therefore as long as the clock module has the standard 1PPS time, it will use the time information based on the acquired GPS time and can be available within 3 minutes.

When the leap second changes, the clock module will change the time information automatically using its internal algorithm so that the time accuracy is maintained and the system can work without manual intervention.

8. How long does it take for a module with an inbuilt GPS receiver to achieve GPS lock?

In general when there is a good satellite signal then the time to achieve a good 1PPS signal will be within 1 to 3 minutes. If the module fails to achieve lock within 3mins then check that the aerial is installed correctly. After obtaining GPS lock, the module will capture the 1PPS signal and begin to continuously adjust the accuracy of the high stability crystal oscillator. Usually the phase offset will be no more than 100ns within 5 minutes of capturing the 1PPS signal.

9. What is the format of the clock module output message?

The output message format of the clock modules is a serial communication with a baud rate of 9600, consisting of 8 data bits and 1 stop bit. The output message of the clock module with an internal GPS receiver follows the GPS standard protocol NMEA-0813. The NMEA message provides NMEA sentence information including codes. GPRMC, GPVTG, GPGGA, GPGSA, GPGLL, GPZDA.

Clock Module Output Timing Information

The main output signal timing sequence of IQD Frequency Products Clock Modules are shown in the following diagrams. When the module is locked and synchronized to the GPS signal then the output signal sequence will as shown in figure 1.4

By default, the pulse width of the GPS standard 1PPS is 100ms and the pulse width of the 10MHz 1 PPS derived signal is also 100ms. The 10MHz signal output rising edge is synchronized with the 1PPS rising edge.

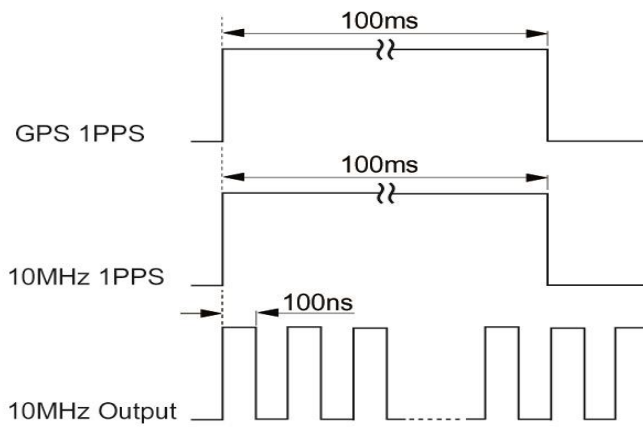

Fig 1.4 Output Timing Sequence

The corresponding output message content is shown in figure 1.5 and the time span of the output message is related to the protocol's content.

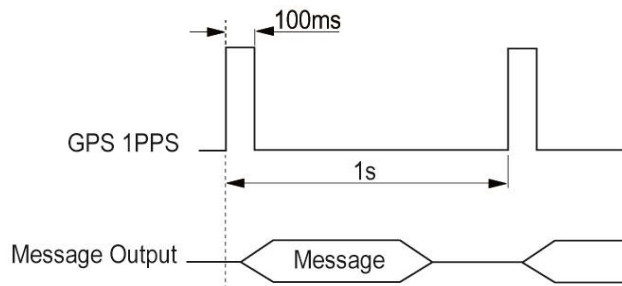

Fig 1.5 Output Timing Sequence



The Output Message of Serial Port TX

The Clock Modules have a range of different output data information formats depending upon the model in question.

The IQCM-100 and IQCM-200 output a data word containing information such as whether the unit is locked to 1PPS input, How long it has been locked, the phase difference between the 1PPS input and 1PPS output. This data is output in standard UART format.

The IQCM-300 outputs the same data word as the IQCM-100 and IQCM-200. In addition it also outputs Precision Time Protocol (PTP) data in SGMII format.

The IQCM-110 outputs standard GNSS data words GPRMC, GPVTG, GPGGA, GPGSA, GPGSV, GPGLL, GPZDA these are output in the standard NMEA format used for GNSS communications. Full details are below.

NMEA Protocol Introduction:

The NMEA protocol is a communication format established by the National Marine Electronics Association for the purpose of establishing a unified RTCM (Radio Technical Commission for Maritime Services) standard in different GPS systems.

According to the criteria of the NMEA-0183 protocol, the GPS receiver sends position, speed and other information to a PC, PDA or other connected equipment through the serial port. The NMEA-0183 is a standard protocol so the GPS receiver should be compliant as it is the most widely used GPS receiver protocol.

The most common GPS receivers, GPS data processing software and navigation software are compliant with or at least compatible with this protocol.

The NMEA protocol format specification as follows:

The Frame Header \$	Protocol Class	Protocol ID	{,<data>}	*<checksum>	Frame end <CR><LF>
1 byte	2 bytes	3 bytes	Indefinite length	2 bytes	2 bytes

The frame header: 1 ASCII characters, '\$' (0x24)

Protocol class: 2 ASCII characters, such as 'GP'(0x47 0x50)

Protocol ID:3 ASCII characters, such as 'RMC '(0x52 0x4D 0x43)

Data: Indefinite length, separated by ','

Checksum: 2 ASCII characters represent 1 byte hexadecimal number, '\$' and '*' between all the characters XOR operation results

Frame end: 2 ASCII characters, represent Enter Wrap <CR><LF> (0x0D 0x0A)

Common standards of NMEA sentence protocol



GPRMC

Description: Recommended Minimum Data (RMC) recommended positioning information.

Format: \$GPRMC,<1>,<2>,<3>,<4>,<5>,<6>,<7>,<8>,<9>,<10>,<11>,<12>*hh<CR><LF>

- <1> UTC time, hhmmss (when) format
- <2> Positioning state, A = Effective positioning, V= Invalid location
- <3> Latitude ddm.mmmm (degree) format (the 0 in front will also be transmitted)
- <4> Latitude hemisphere N (northern hemisphere) or S (southern hemisphere)
- <5> Longitude (dddmm.mmmm degree) format (the 0 in front will also be transmitted)
- <6> Longitude hemisphere E(East longitude)or W(West longitude)
- <7> Ground speed (section 000.0~999.9,the 0 in front will also be transmitted)
- <8> Ground course (000.0~359.9 degrees, with one for reference, the 0 in front will also be transmitted).
- <9> UTC date, ddmmyy (DMY) format
- <10> Magnetic declination (000.0~180.0 degrees), the default does not output
- <11> Magnetic declination direction, E (East) or W (West), the default does not output
- <12> The mode indication (only NMEA0183 version 3 output, A=autonomous positioning, D= differential, E= estimation, N = data is invalid)

GPVTG

Description: Course over ground and Ground Speed (VTG) ground speed information.

Format: \$GPVTG,<1>,T,<2>,M,<3>,N,<4>,K,<5>*hh<CR><LF>

- <1> The ground course reference to the north the datum (000~359 degrees, the 0 in front will also be transmitted)
- <2> The ground course reference to the magnetic north for the datum (000~359 degrees, the 0 in front will also be transmitted)
- <3> Ground speed (000.0~999.9 section, the 0 in front will also be transmitted)
- <4> Ground speed (0000.0~1851.8 km / h, the 0 in front will also be transmitted)
- <5> The mode indication (only NMEA0183 version 3 output, A=autonomous positioning, D= differential, E= estimation, N= data is invalid)



GPGGA

Description: Global Positioning System Fix Data (GGA) GPS The location information.

Format: \$GPGGA,<1>,<2>,<3>,<4>,<5>,<6>,<7>,<8>,<9>,M,<10>,M,<11>,<12>*hh<CR><LF>

- <1> UTC time, hhmmss.ss (hour minute second) format
- <2> Latitude ddmn.mmmm (degree) format (the 0 in front will also be transmitted)
- <3> Latitude hemisphere N (northern hemisphere) or S (southern hemisphere)
- <4> Longitude (dddmm.mmmm degree) format (the 0 in front will also be transmitted)
- <5> Longitude hemisphere E(East longitude)or W(West longitude)
- <6> The GPS state: 0= not positioning, 1= non differential positioning, 2= differential positioning, 6= estimating
- <7> The number of satellites which are calculating the position (00~12)
(the 0 in front will also be transmitted)
- <8> HDOP horizontal dilution of precision (0.5~99.9)
- <9> Altitude (-9999.9~99999.9)
- <10> The height of Earth ellipsoid relative geoid
- <11> The differential time (the number of seconds start from the recent differential signal received and if it is not the differential positioning the time will be null)
- <12> The differential station ID number 0000~1023 (the 0 in front will also be transferred, if it is not the differential positioning will be null)

GPGSA

Description: GPS DOP and Active Satellites (GSA) The current satellite information.

Format: \$GPGSA,<1>,<2>,<3>,<3>,<3>,<3>,<3>,<3>,<3>,<3>,<3>,<3>,<3>,<3>,<4>,<5>,<6>*hh<CR><LF>

- <1> Model M= manual, A= automatic
- <2> Positioning type, 1= no positioning, 2=2D positioning, 3=3D positioning
- <3> PRN code (PN code), are used for calculating position of the satellite signal (01~32,the 0 in front will also be transmitted)
- <4> PDOP position accuracy factor (0.5~99.9)
- <5> HDOP horizontal dilution of precision (0.5~99.9)
- <6> VDOP vertical dilution of precision (0.5~99.9)



GPGSV

Description: GPS Satellites in View (GSV) visible satellite information

Format: \$GPGSV,<1>,<2>,<3>,<4>,<5>,<6>,<7>,...<4>,<5>,<6>,<7> *hh<CR><LF>

<1> The total number of GSV statements

<2> The number of current GSV

<3> The total number of visible satellites (00~12,the 0 in front will also be transmitted)

<4> PRN code (pseudo random noise code (01~32), the 0 in front will also be transmitted)

<5> The satellite elevation (00~90 degrees, the 0 in front will also be transmitted)

<6> Satellite azimuth (000~359 degrees, the 0 in front will also be transmitted)

<7> The signal-to-noise ratio (00~99dB, no track to the satellite as an empty, the 0 in front will also be transmitted)

Note: <4>, <5>, <6>, <7> information will be displayed according to each satellite for cycle, each GSV sentence can display up to 4 satellites information. Other satellites' information will be output in the next sequence in the NMEA0183 sentence.

GPGLL

Description: Geographic Position (GLL) location geographic information

Format: \$GPGLL,<1>,<2>,<3>,<4>,<5>,<6>,<7>*hh<CR><LF>

<1> Latitude ddmm.mmmm (degree) format (the 0 in front will also be transmitted)

<2> Latitude hemisphere N (northern hemisphere) or S (southern hemisphere)

<3> Longitude (dddmm.mmmm degree) format (the 0 in front will also be transmitted)

<4> Longitude hemisphere E(East longitude)or W(West longitude)

<5> UTC time, hhmmss (hour minute second) format

<6> Positioning state, A= the effectiveness positioning, V= the positioning is invalid

<7> The mode indication (A= autonomous positioning, D= differential, E= estimation, N= data is invalid)



GPZDA

Description: Time and Date (ZDA) time and date

Format: \$GPZDA,<1>,<2>,<3>,<4>,<5>,<6>*hh<CR><LF>

<1> UTC time, hhmmss (hour minute second) format

<2> UTC date, day, DD format

<3> UTC date, month, mm format

<4> UTC date, year, yyyy format

<5> The local time zone hours (not currently support, fixed for 00)

<6> The local time zone the number of minutes (not currently support, fixed for 00)

Glossary:

PPS	Pulse per Second
GPS	Global Positioning System
OCXO	Oven Controlled Crystal Oscillator
Holdover	Ability of device to retain timing accuracy without GPS lock
NMEA	National Marine Electronics Association
PTP	Precision Time Protocol (IEEE-1588)
SGMII	Serial Gigabit Media Independent Interface (protocol connectivity between physical layer (PHY) and Ethernet media controller (MAC))
SPI	Serial Peripheral Interface (4 wire synchronous serial data link)
DAC	Digital to Analogue Conversion
LTE	Long Term Evolution
UTC	Universal Coordinated Time